

6

5

4

3

2

1

**MATERIAL AND FINISH:**

Fiber board: Fiber, UL-94V-HB rated

Cover: PVC, black

Wire leads: PVC, 26 AWG

Snaps: Brass, Nickel plated

**RoHS  
COMPLIANT**

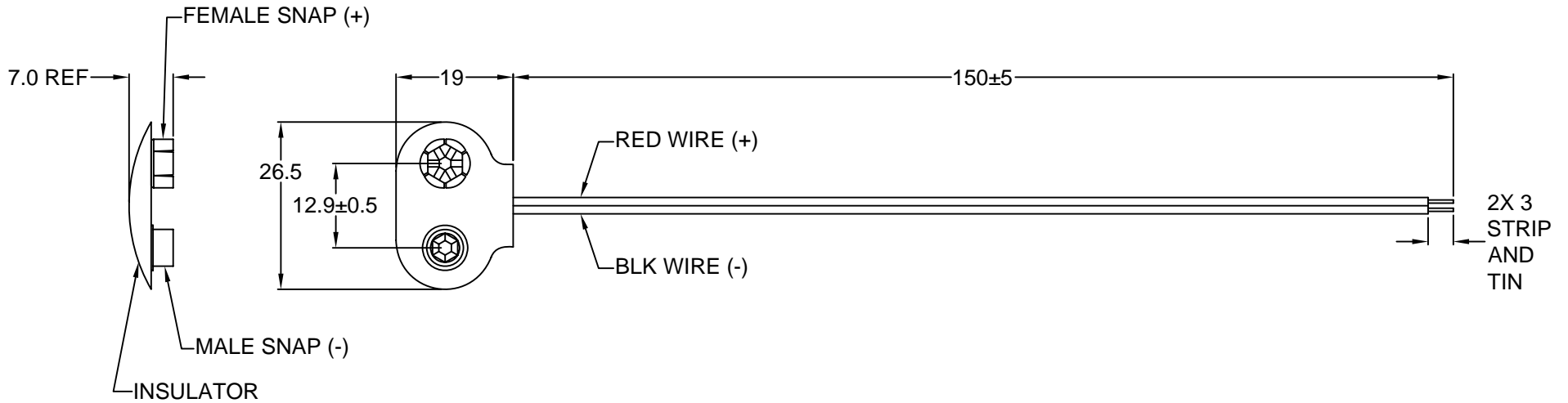

REV	DATE	CHANGE	WIRE COLOR REVERSED	CHNG	CHECK	APPR
				TD	PB	
A	3/14/03					

**REVISIONS**

TOLERANCE UNLESS OTHERWISE SPECIFIED		
X	±	1
X.X	±	0.4
X.XX	±	0.20
DRAWN BY	GQ	DATE: 06/10/02
CHECK BY	TD	DATE: 07/23/02
APPR BY	PB	DATE: 07/23/02

**Power Dynamics, Inc.**  
Phone: 973 560-0019 Whippany, New Jersey Fax: 973 560-0076

**PART: 9V BATTERY SNAP  
WITH PVC COVER**

<b>PDSN-4</b>		SHEET 1 of 1
PART #:		
SIZE: A	ALL DIMENSIONS FOR REFERENCE ONLY DIMENSIONS ARE IN MILLIMETERS	
SCALE: NTS	REV:	

6

5

4

3

2

1